



FIREWARM INSET STOVE

5kW Nominal Output

FW5C

Installation and Operating Instructions

Please hand these instructions to the stove user when the installation is complete. Leave the stove ready for operation and instruct the user in the correct use of the appliance and operation of controls.

Important: – This product must be installed by a suitably qualified installer.

Heat Design

30 – 60 Hawthorn Road
Western Industrial Estate
Naas Road
Dublin 12

www.heatdesign.ie

PLEASE READ ALL THESE INSTRUCTIONS CAREFULLY!

For safety reasons it is essential that your stove is correctly installed and operated. Firewarm Stoves cannot accept responsibility for any fault or consequential problems arising through incorrect installation or operation.

TABLE OF CONTENTS

Section	Page No
1. List of Components	2
2. Component Identification and Assembly	2
3. Installation Instructions	3
3.1 Warnings and important safety information	3
4 Installation Information	4
4.1 Chimney	4
4.2 Ventilation	4
4.3 Flue Draught	5
4.4 Connection to Chimney	5
4.5 Material Clearances	5
4.6 Fixing	5
4.7 Hearths	6
4.8 Commissioning & Handover	6
5. Technical Data	6
6. Operating Instructions	6
6.1 Air controls	7
6.2 Cleaning	8
6.3 Fuels	8
6.4 Notes on Wood Burning	8
6.5 Lighting the stove	9
6.6 Re-fuelling	9
6.7 Shutting down	9
6.8 Maintenance	9
7. Safety Notes for your Guidance	10
8. Frequently Asked Questions	11

1. List of Components

Description of Parts	Qty
FW5C Stove Assembly	1
Tool	1
Ash Pan	1
Flue Collar	1
Flue Collar fixing screws	4
Stove Operating Glove	1
Touch up paint	1
Warranty Card	1

Fig 1 – Stove Tool

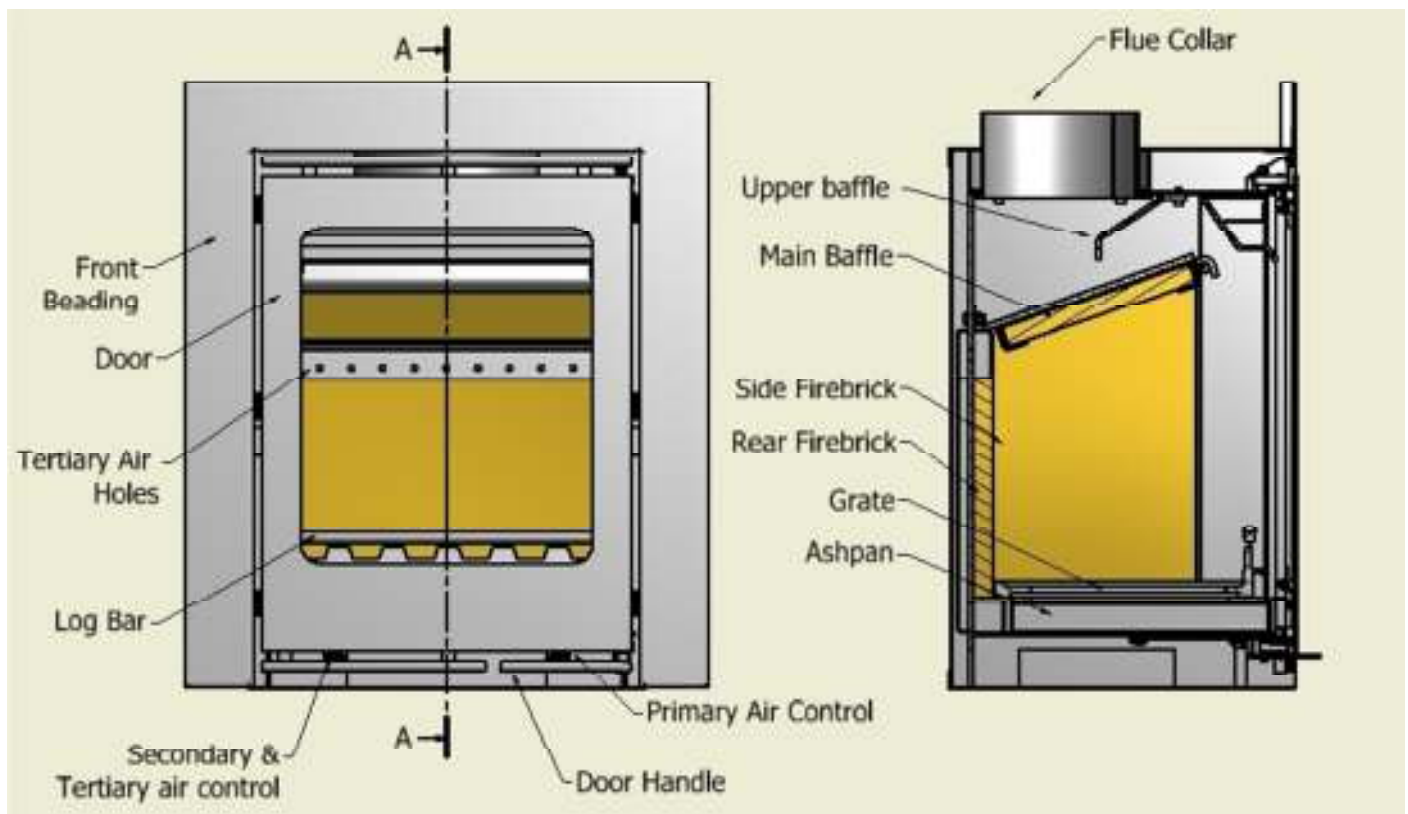
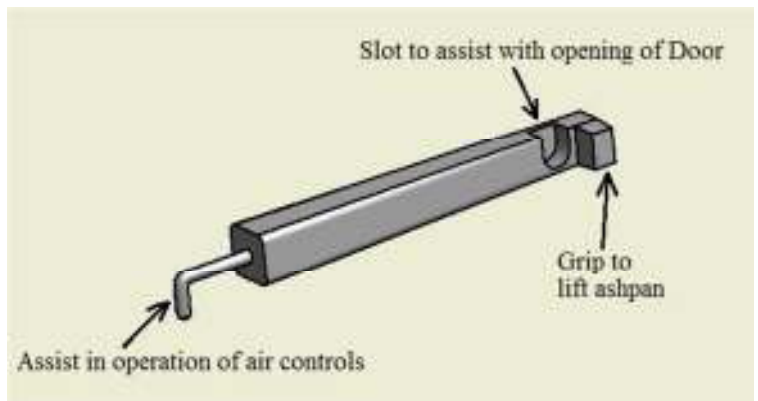

Fig 2 – FW5C Stove Assembly and controls

2. Component Identification and Assembly

Your Firewarm Cassette Stove comes packed in a cardboard box. Carefully remove any straps and remove all cardboard and any plastic packaging, open the door and remove all the contents. See List of Components section and check contents carefully.

- 2.1 To remove the baffle plate, carefully lift the hooks at the front up and over the pegs and slide the baffle down and remove through the front door. Then remove the two side firebricks and the two rear firebricks. Handle & store very carefully to one side where they will not get broken.
- 2.2 Now lift up the grate and carefully remove this from the stove.
- 2.3 Now proceed to install the stove according to these instructions and current installation standards or HETAS advice. The internal parts of the stove can be re-assembled as the reverse of the previous removal instructions.

3 Installation Instructions

3.1 WARNINGS AND IMPORTANT SAFETY INFORMATION

3.1.1 READ THESE INSTRUCTIONS CAREFULLY BEFORE INSTALLATION!

These instructions cover the basic principles to ensure satisfactory installation of the stove, although detail may need slight modification to suit particular local site conditions. In all cases the installation must comply with current local regulations including Building Regulations, Local Authority Byelaws and other specifications or regulations including Ireland, UK or EU standards referred to as they affect the installation of the stove. Approved Document J is particularly important for England and Wales and can be downloaded for no cost at:

<http://www.planningportal.gov.uk/england/professionals/en/400000000503.html> Also of importance are Approved documents L1 A and B conservation of fuel and power. The Domestic Heating Compliance Guide will also be found useful.

3.1.2 Important Chimney Warning

This stove must not be installed into a chimney that serves any other heating appliance.

3.1.3 Extractor Fan Warning

There must not be an extractor fan fitted in the same room as the stove as this can cause the stove to emit fumes into the room.

3.1.4 Cleaning and Chimney Sweeping

The appliance, flue & chimney must be cleaned and checked internally and externally regularly in use and especially after a period on disuse (e.g. after summer). Lift down the baffle at least weekly to check for build up of soot or debris on the top from the flue pipe. Remove the baffle and check the flue spigot and connector is fully clear at regular intervals. The chimney and flue connector must be swept at least annually, more often when used with sooty fuels or damp wood. Any loose, broken or leaking joints or flue ways **MUST** be repaired immediately.

3.1.5 Fuels

Only use recommended fuels. The appliance can be damaged by burning petroleum coke, liquid fuels or general rubbish and this will invalidate your warranty and risk your personal safety. **The appliance must not be used as a rubbish incinerator.**

3.1.6 Maintenance

Annual checking and servicing of the appliance and flue by a competent engineer is recommended.

3.1.7 Ventilation

Adequate ventilation is **ESSENTIAL** for the safe and efficient operation of any solid fuel or wood burning appliance. Ventilation **MUST** be provided where required by the stove output or flue under-performance. Keep all ventilation clear and free of blockage.

Health And Safety Precautions

3.1.8 Handling

Adequate facilities must be available for unloading and site handling. Firewarm Cassette Stoves are very heavily built so always ask for assistance when lifting and siting the stoves.

3.1.9 Fire Cement

Some types of fire cement are caustic and should not be allowed to come into contact with the skin. In case of skin contact, wash immediately with plenty of water.

3.1.10 Asbestos

This stove contains no asbestos. If there is a possibility of disturbing any asbestos in the course of installation then please seek specialist guidance and use appropriate protective equipment.

3.1.11 Metal Parts

When installing or servicing this stove, proper care should be taken to avoid the possibility of personal injury.

4.0 Installation Information

4.1 Chimney

The chimney height and the position of the chimney terminal should conform to Building Regulations. Minimum chimney height is 4.5m. Check that the chimney is in good condition, dry, free from cracks and obstructions. The diameter of the flue should not be less than 150mm and not more than 200mm. If any of these requirements are not met, the chimney should be lined by a suitable method. The chimney must be swept before connection to the stove.

Where the chimney is believed to have previously served an open fire installation, it is possible that the higher flue gas temperature from the stove may loosen deposits that were previously firmly adhered, with the consequent risk of flue blockage. It is therefore recommended that the chimney be swept a second time within a month of regular use after installation.

If you have any doubts about the suitability of your chimney, consult your local dealer/stockist or chimney specialist. If there is no existing chimney then either a solid fuel compatible prefabricated block chimney or a twin-walled insulated stainless steel flue to BS 4543 can be used. These chimneys must be fitted in accordance with the manufacturer's instructions and Building Regulations.

4.2 Ventilation

Purpose provided ventilation is recommended, however, it is not required in England and Wales unless the appliance rated output is greater than 5kW. Over 5kW 5.5 cm² of ventilation (550mm²) is required for every kW output above 5. For example 6.5 kW requires 8.25 cm² and 8 kW needs 16.5cm². In any case, if difficulty in starting the fire or any fuming is experienced, ventilation must be put in place as required to eliminate these flue problems. If a flue draught stabiliser is fitted then extra ventilation is required – see Document J of the Building Regulations.

4.3 Flue Draught

A flue draught of minimum 1.2mm to a maximum 2.5mm water gauge (12 to 25 Pascals) is required for satisfactory appliance performance. The flue draught should be checked under fire at high output and, if it exceeds the recommended maximum, a draught stabiliser must be fitted so that the rate of burning can be controlled to prevent over-firing.

4.4 Connection to the Chimney

This appliance is **not** suitable for use in a shared flue. This appliance requires a direct flue connection to the spigot. If practical, an existing fireplace opening can be bricked up or sealed with a register plate and a short length of flue pipe of a minimum 150mm internal diameter may then be used to connect the stove to the register plate in the chimney. This flue pipe should conform to Building Regulations. The stove must be insulated and properly fitted into the fireplace opening by back filling with 6:1 ratio vermiculite & cement mixture using minimal water through the top of the fireplace or flue spigot opening. The surface should be finished using 1:1:8 mix of cement, lime and sand. The connecting pipe is fitted with the spigot pushed up from **inside** the stove and rotated onto its keyhole slots to join to the pipe. Ensure that the pipe end is no closer than 76mm to the side or rear chimney walls.

If necessary a hole must be opened up into the flue way above the fireplace in order to fit the appliance to the flue correctly. Please consult HETAS recommended fitting methods if in doubt. It is **essential** that all connections between the stove and chimney-flue are sealed and made airtight with sealing rope, clamping rings and/or fire cement or heat resisting cement where required.

Both the chimney and flue pipe must be accessible for cleaning and if ANY parts of the chimney cannot be reached through the stove (with baffle removed), a soot door must be fitted in a suitable position to enable this to be done.

4.5 Fixing

Fix the stove to the back hearth using suitable non-combustible fixings through the base of the outer firebox. If necessary screw the outer firebox to the back-panel by fixing the top or side flanges using suitable non-combustible fixings.

4.6 Material Clearances

Safety Distances from Combustible Surfaces:

Model	Shelf	Side (outer edge of trim)
FW5C	250mm	350mm

In addition it is strongly recommended that any furniture or other combustible materials are kept at least 900mm clear from the front of the stove.

Distances from NON-combustible materials:

The stove can be recessed in a suitable sized non-combustible fireplace but a permanent free air gap of at least 50mm must be left around the sides and top of the stove to obtain reasonable heat output and for access to the stove for removal and maintenance. A clearance of 150mm will give a better heat output

To conform with building regulations the fireplace recess walls should be at least 200mm thick or each rear leaf at least 100mm thick in the case of a cavity wall at the rear. If these dimensions are not met further protection for any combustible materials must be provided. The walls of the fireplace recess and the hearth must be made of non-combustible material.

4.7 Hearths:

The FW5C stove require a 125mm thick non-combustible constructional hearth beneath them to protect the building, this can include any solid non-combustible floor. A non-combustible superimposed hearth forming an apron of at least 225mm at the front of the stove and 150mm on either side must also be provided. The superimposed hearth must not be less than 12mm thick and must have a clearly defined edge (change of level) to discourage placing of any combustible materials on or partially over it.

The appliance shall be installed on a floor with adequate load-bearing capacity. If the existing construction does not meet this requirement, suitable measures (e.g. load distributing plate) should be provided to achieve it.

4.8 Commissioning and Handover

Upon completion of the installation, allow a suitable period of time for any fire cement and mortar to dry out. A small fire may then be lit and checked to ensure the smoke and fumes are taken from the stove up the chimney and emitted safely to atmosphere.

Advise the customer not to run the stove at full output for at 3 – 4 days. Explain that the stoves can provide much more or less than their rated heat outputs depending upon how they are burnt and fuels and fuel loads used.

On completion of the installation and commissioning, ensure that the operating instructions and operating tools (including glove) for the stove are left with the customer. You must be sure to advise the customer on the correct use of the appliance with the fuels likely to be used on the stove and warn them to use only the recommended fuels for the stove.

Advise the user on what to do should smoke or fumes be emitted into the room from the stove – see **Safety Notes** section. The user should be warned that they **MUST** use a suitable fireguard in the presence of children, aged and/or infirm persons.

5.0 Technical Data

Model	FW5C
Appliance weight (Kg):	66.5
Efficiency (%) on Wood fuel	80.4
Declared nominal output (kW)	5
Tested re-fuelling interval (h)	1
Flue gas mass flow: (g/s)	4.2
*Flue Temp: (Deg C)	259
Max Log Length:	310mm

*Average reading at nominal output

6.0 Operating Instructions

This appliance is not designed for open operation and therefore should **not** be operated with the doors open.

This stove is designed to burn cleanly with high efficiency. If used correctly this stove will burn with the very useful feature of clean glass. However, for this product to work properly it must be used correctly.

It is **essential** that the stove has an adequate air supply for combustion and ventilation. The primary, secondary and tertiary air inlets must be kept clear from obstruction.

Warning! This appliance will be very **hot** when in operation and due care should be taken when operating the controls. A leather glove is provided to assist safe operation.

Do not use an aerosol spray on or near the stove when it is alight.

6.1 Air Controls

Primary Air

Primary air is controlled via the sliding air control at the bottom right of the stove, just below the door. This provides a conventional air under draught to the bed of the fire. The primary air is used when lighting the stoves or when the fuel bed goes very low. Once the stove is properly lit the primary air should be fully closed.

Secondary Air (Air Wash)

Firewarm Cassette stoves are provided with a sophisticated preheated “air wash” system. This secondary air supply to the stove is controlled via a sliding air control located on the bottom left of the stove, just below the door. If you want clean glass, always leave this control open some way whilst burning unless the stove is being shut right down for a long period. Moving the sliding control towards the wide side of the arrow increases the burn rate whilst moving it towards the narrow side reduces it.

Tertiary Air

This appliance is also fitted with a preheated tertiary air system controlled via a sliding control located on the bottom left of the stove just below the door (same as secondary air). Moving towards the wide side of the arrow increases the tertiary air supply whilst moving towards the narrow side reduces it. It burns otherwise uncombusted gases in the products of combustion thereby improving efficiency, increasing heat output and decreasing unwanted atmospheric emissions. At certain stages of burning you will notice “jets” of flame emerging near the air holes to the rear of the firebox.

Multifuel Grate

This stove is fitted with a grate with a strong set of cast iron bars with suitable air slots and will burn most fuels. When burning coal type fuels it is important to stoke the fire well where required to de-ash regularly, to ensure that the primary airflow is not impeded, as a build-up of ash *when burning coal* can damage the cast iron grate. A build up of ash when burning wood will not usually harm the grate and indeed wood burns better on a bed of wood ash building up. Excessive wood ash build up is not to be recommended however as this would decrease the size of the firebox and consequently decrease the amount of fuel that can be put in the stove.

Ashpan

It is essential that you empty the stainless steel ash pan every day. Use the thick end of tool to hook onto and lift the ash pan out of the stove. **DO NOT allow ash to build up underneath the bed as this may cause damage to the grate.**

6.2 Cleaning

Glass: Despite the advanced air wash system provided, the glass will still need cleaning from time to time depending on the fuel quality and burning rates used. Never clean glass when the stove is hot. Always use stove glass cleaner or ceramic hob cleaner, which is available from your stove retailer. As an alternative, use a wet cloth with some of the wood ash if burning wood but be very careful to use very clean ash so as not to scratch the glass.

Outer body: The outer body simply needs to be dusted from time to time. DO NOT use any kind of furniture polish or cleaning agent other than your stove suppliers recommended paint.

Inner firebox: Brush the inside of the firebox clean from time to time to check the integrity of the plates and liners etc. It is not normally necessary to re-paint inside the firebox due to the high temperatures that mean that the paint does not have much effect before being burnt off. Steel and vermiculite board liners are resilient firebox materials and will give reliable service without major cleaning or work on the firebox. The liner boards may require replacement fairly regularly depending upon fuels and the type of usage experienced. Lining boards are not covered by warranty, as they are a wearing consumable part.

Baffle: It is essential to check the top of the baffle for build up of soot and ash regularly when in use and after a long period of no use. From time to time remove the baffle if necessary to ensure that the flue way entrance is clear.

6.3 Fuels

The appliance is fitted with a versatile multifuel grate, however the appliance has been tested and approved burning dry, well-seasoned logs. This is the recommended fuel.

6.4 Notes on Wood burning

With a full load of wood, the stove will need to be refuelled approximately every 1 to 1.5 hours depending on burn rate. Wood can be stacked in the stove but care must be taken that logs do not touch the baffle. Do not stack fuel above the level of the tertiary air inlets at the back of the stove.

Wood burns most efficiently with the primary air controls closed and the secondary (air wash) controls open. Carefully adjusting the secondary air controls and fuel load will then control the burn rate of the stove. Always make sure that flames are visible above the wood after re-fuelling for cleanest burning. Open the air wash full for 3 to 5 minutes to achieve full flames above the fuel.

See also: section entitled ‘Lighting the Stove’.

Wood burns best on a bed of ash and it is therefore only necessary to remove surplus ash from the stove occasionally. **If the grate is completely clear, place a few handfuls of ash into the slots in the grate to help the firebed build up.**

Burn only dry, well-seasoned wood, which should have been cut, split and stacked - under protection from rain - for at least 12-24 months with free air movement around the sides of the stack to enable it to dry out. Burning wet or unseasoned wood will create tar deposits in the stove and chimney and will not produce a satisfactory heat output. **Wood that is not properly dry (‘dry’ is considered to be less than 20% internal moisture content) uses up energy from the burn process to evaporate the water inside the wood thus creating very poor conditions for combustion.** The main cause of burning problems with wood stoves is due to excessively damp wood. Wood can appear perfectly dry on the outside but still contain 40-50% water on the inside. A moisture meter can be purchased from some stove and equipment suppliers if you wish to check your wood source is correct.

6.5 Lighting the Stove

We recommend that you have two or three small fires before you operate your stove to its maximum heat output. This is to allow the paint to cure in steadily and to give a long service life of the paint finish. During this curing in process you may notice an unpleasant smell whilst the finishes finally cure. It is non-toxic, but for your comfort we would suggest that during this period you leave all doors and windows open.

First, open the primary and secondary air wash control fully. Load the firebox with plenty of starting fuel, i.e. paper, dry sticks and/or firelighters. Light the fire at the base leaving the primary and secondary air control fully open. Leave the door slightly ajar for 10 minutes to enhance initial starting and reduce smoke emission – DO NOT leave the stove unattended if the door is left ajar. Allow the fuel to reach a steady glow and build the fire up gradually by adding a few small sticks or well split logs at a time. Once you have a good fire bed established across the grate, further fuel can be added step by step as required. Don’t be tempted to overload the fire bed with fuel all at once or close down the air controls too much until the fire is really well established for some time. Once the ignition period is well under way close the primary air and gradually reduce the secondary air wash control opening to establish the burning intensity you require.

6.6 Re-fuelling

When burning wood, the fire will die down as the fuel is consumed. When the flames disappear and the remainder is breaking down into glowing embers it is an appropriate time to consider re-fuelling. NOTE: If the flames disappear and there are still lumps of solid wood left this indicates excessive moisture in the wood or insufficient air supply/flue draught.

Note: To eliminate unwanted smoke emission, after loading new logs on to the fire, open the air wash control up fully for 3-5 minutes to boost the fire and get flames issuing from the top of the fuel as soon as possible. When flames are well established, reduce the air wash to the running setting required. Burning without flames above the fuel will create unnecessary smoke. Do not load fuel above the tertiary air inlet holes at the back of the firebox.

Loading 3 to 4 medium sized logs will produce a good output with reasonable burn time, generally small logs will burn up quicker producing a high output for a short time and a large log will take longer to burn and produce less output over a given time. These appliances are approved for intermittent operation on wood (0.75 to 1.5 hour burn cycles) although much longer burn times can be achieved by fully loading the firebox, getting the fuel burning well and then shutting the air controls down. The fire will then often need reviving by first de-ashing and then using small pieces of wood and plenty of air to get flames issuing from the wood again.

6.7 Shutting Down

The stove will normally shut down by itself as the fuel is consumed. In order to shut down the stove for other reasons, close the primary air controls (if open), then close the secondary air control. If the controls are left in this position, the fire will eventually burn out. If you want to revive the fire open the secondary air controls fully.

Warning! - The stove will remain **very hot** for a considerable time after the fire has died down or been extinguished.

Warning!- **Petroleum coke fuels or household waste must not be burnt on this appliance.**

6.8 Maintenance

Inspect the inside of the firebox and above the baffle plate every week during use. **See chimney cleaning section in section 3.1 Warnings and Important Information.** Inspect the inside of the stove and the flue ways and ensure they are 100% clear after a period of disuse (e.g summer). **Only use manufacturers recommended replacement parts on the appliance**

7.0 Safety Notes for your guidance

FIRES CAN BE DANGEROUS – Always use a fireguard in the presence of children, the elderly or the infirm.

DO NOT perform modifications to the appliance as this could seriously compromise safety in operation.

DO NOT OVERFIRE – it is possible to fire the stove beyond its design capacity, this could damage the stove, so watch for signs of over firing – if any part of the stove starts to glow red, the fire is in an over fire situation and the controls should be adjusted accordingly. Never leave the stove unattended for long periods without first adjusting the controls to a reduced and safe setting – careful air supply control should be exercised at all times.

WARNING – FUME EMISSION

Properly installed and operated, this appliance will not emit fumes. Occasional fumes from de-ashing and refuelling may occur which is not normally of serious concern. **However, persistent fume emission is potentially dangerous and must not be tolerated.**

If fume emission does persist, then the following immediate action should be taken: -

1. Open doors and windows to ventilate room
2. Let the fire out, or remove and safely dispose of fuel from the appliance.
3. Check for flue chimney blockage and clean if required.
4. Do not attempt to re-light the fire until the cause has been identified and corrected.

If necessary, seek professional advice from chimney or stove specialists.

Important! – Do not fit an extractor fan in the same room as this appliance.

IN THE EVENT OF A CHIMNEY FIRE

- Raise the alarm to let others in the house know.
- Call the Fire Brigade
- Reduce the appliance-burning rate by closing all air controls fully.
- Move furniture and rugs away from the fireplace and remove any nearby ornaments.
- Place a fireguard or spark guard in front of the stove.
- Feel the chimneybreast for sign of excessive heat.

If the wall is becoming hot, move the furniture away. Ensure that the Fire Brigade can gain access to your roof space in order to check this area for signs of fire spread.

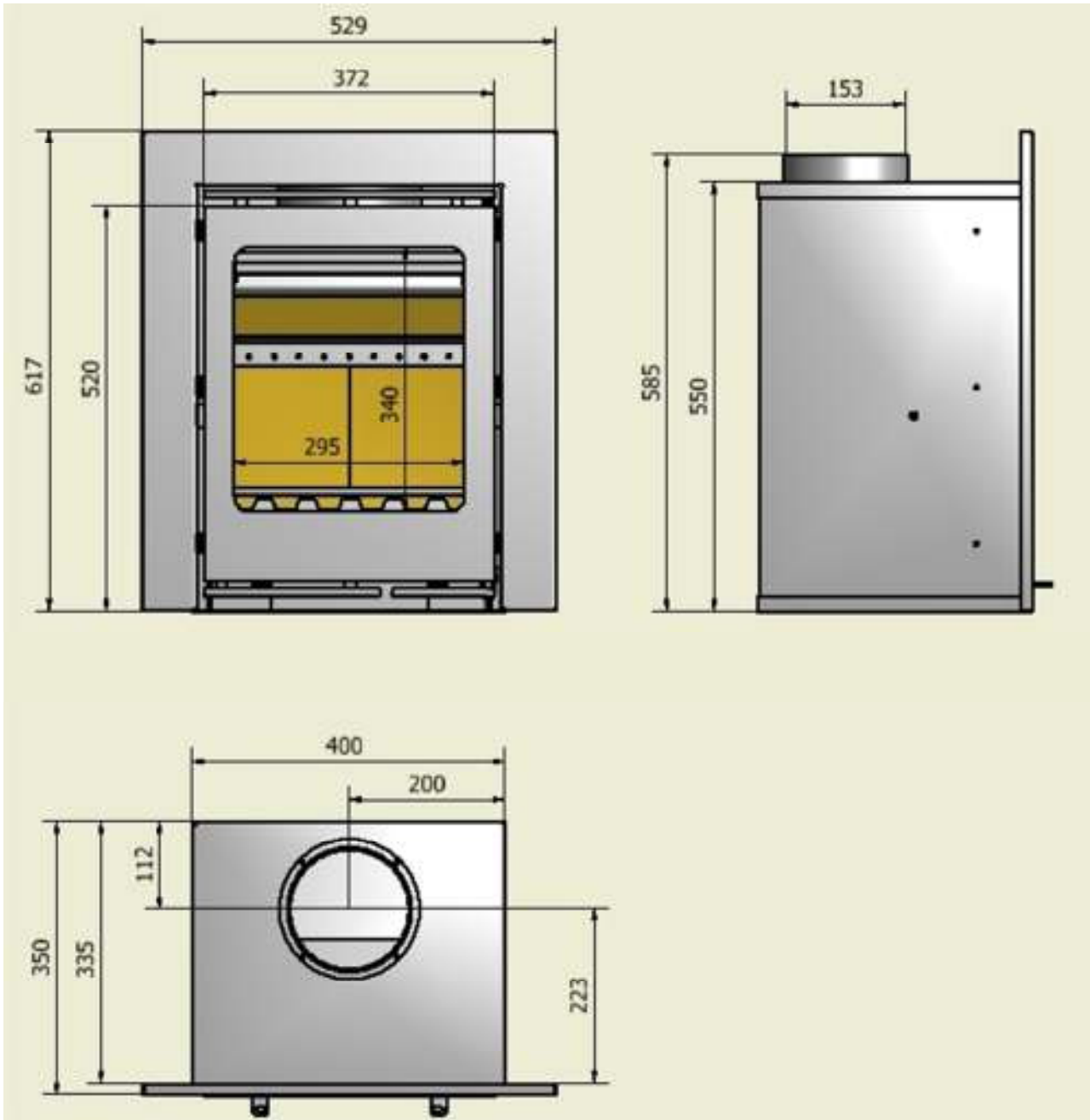

Fig. 3 – FW5C Cassette Stove Dimensions

8.0 Frequently Asked Questions

1 Do stoves require a chimney? All of our multi fuel and wood burning stoves require a suitable chimney or professionally installed flue system.

2 How do I clean the chimney? You will require a chimney sweep to clean the chimney. It is essential to provide a dedicated chimney cleaning access door when installing the flue of the stove in some situations. In other situations the chimney can be swept through the firebox.

3 Who should install my stove? Firewarm Stoves want you to enjoy the maximum performance from your appliance. To ensure this, it is essential that they are installed correctly. We strongly recommend that your stove is installed by a suitably qualified installer e.g HETAS.

4 How do I regulate the heat output? Each stove has various air controls, which will allow you to easily regulate the heat output and refuelling rate.

5 What warranty do I get? Firewarm Stoves will replace, free of charge, any working part that fails (under normal operating conditions) within 12 months of purchase. Consumables such as glass, firebox lining boards or stove rope and adhesives are not guaranteed. ***A call out charge will apply if our engineer attends any stove problem that is not related to product failure.***

6 Where can I get spare parts? Your local Firewarm Stove retailer will be pleased to supply spare parts and to provide any other information you require.

7 Can the doors be left open while burning? For safety and heat efficiency the doors should remain closed.

8 Why is the stove smoking when lit? A flue with back draught problems is almost certainly the cause of a smoking stove. Also check adequate ventilation is present. A qualified fitter should complete both a smoke pressure and flow test prior to fitting the stove to ascertain the integrity of the flue.

9 Why should I “Run in” my stove? To begin, light a series of small fires over a period of a few days to allow the paint finish to cure. The stove is finished with a highly heat resistant paint. The finish can be renovated with stove paint available from your local stove retailer. If the stove is not “run in” correctly, this may cause the paint to discolour and flake.

10 What is Over Firing? Your stove should never be used in a manner to cause over firing. Over firing can be caused by over loading the stove with fuel, and with primary controls open. If any part of stove glows "red" your stove is over firing and your draught control should be adjusted to restrict airflow to stove. Over firing can cause permanent damage to the appliance, which is not covered by warranty.

Heat Design, 30 – 60 Hawthorn Road, Western Industrial Estate, Naas Road, Dublin 12
T: 01 408 9192 **F:** 01 408 9193

